

Mini CIP Custom Intelligent Propeller



Jabiru 80, 120 and 180 HP Engines

Mini Custom Intelligent Propeller for Jabiru Engine

General Description.

Mini CIP, Custom Intelligent Propeller controls automatically and intelligently the pitch of your electric variable pitch propeller.

A **Main Unit** and a **Display Unit**, integrated within one single case, make up the **Mini CIP Custom Intelligent Propeller**.

CIP, Custom Intelligent Propeller schematic diagram

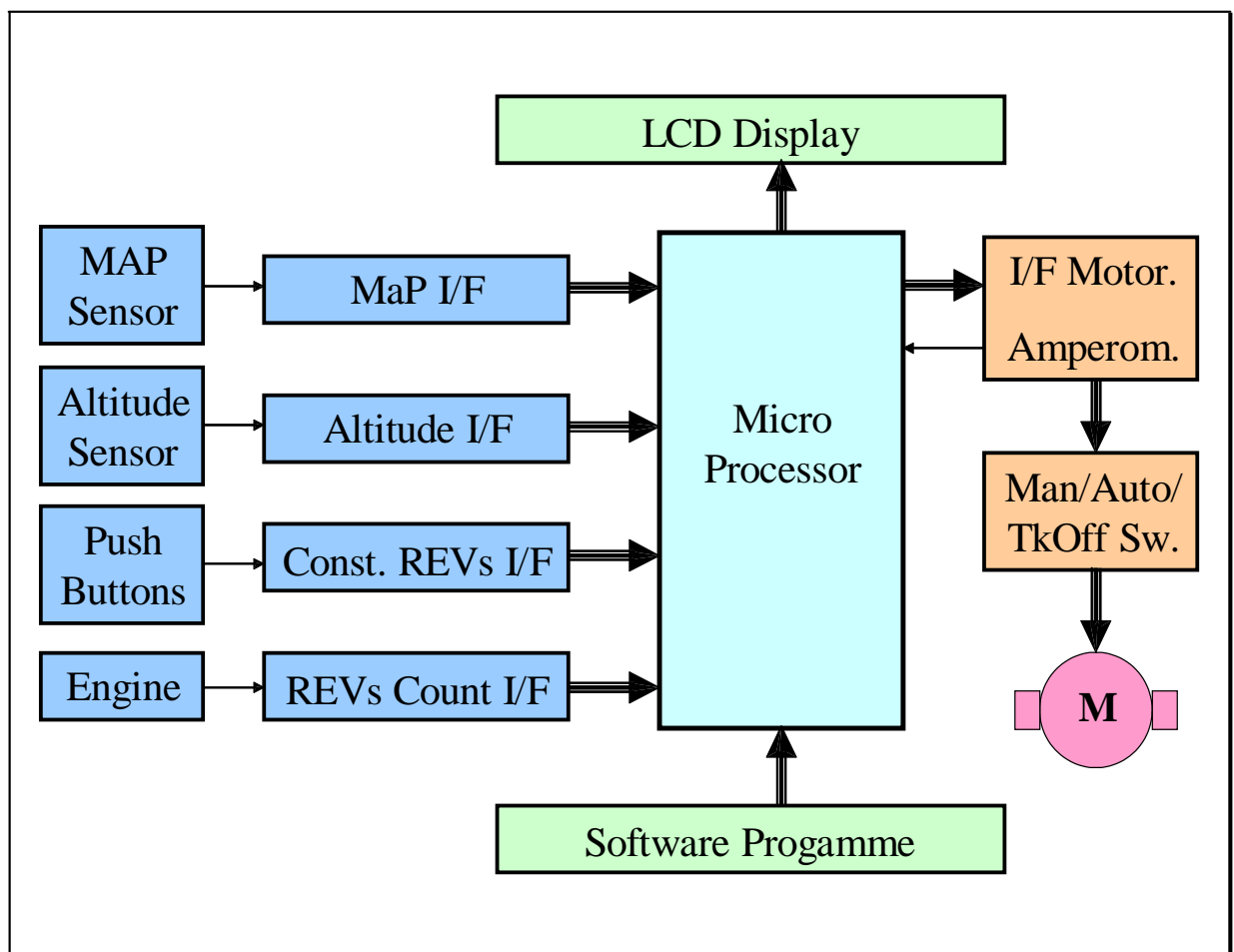

Legend:

- LCD Liquid Christal Display.
- I/F Interface.
- REV's Engine Revolutions
- MaP Manifold Pressure
- Sw Switch
- Push Buttons + -
- Press Pressure

Mini C I P. Custom Intelligent Propeller Main Unit

The **Mini C I P Main Unit** is made up by a two face rectangular Printed Circuit Board.

It contains:

- 1) The Microprocessor that executes the program to control the pitch of your propeller.
- 2) An EEPROM (Electrically Erasable Programmable Read Only Memory) to store the program.
- 3) An EEPROM used as non volatile memory to store the custom parameters associated with the Aircraft model and the adopted propeller type.
- 4) An Analogue to Digital converter necessary to digitalize the input parameters to the microprocessor.
- 5) A digital interface to the Manifold Pressure sensor in Hg inches.
- 6) A digital interface to the Altitude pressure sensor in Hg inches.
- 7) A digital counter to measure the engine Revolutions (Revs).
- 8) An Ampere-meter to monitor the propeller motor current.
- 9) A relay to switch to manual mode.
- 10) Two high current relays used as actuators back / foreword.

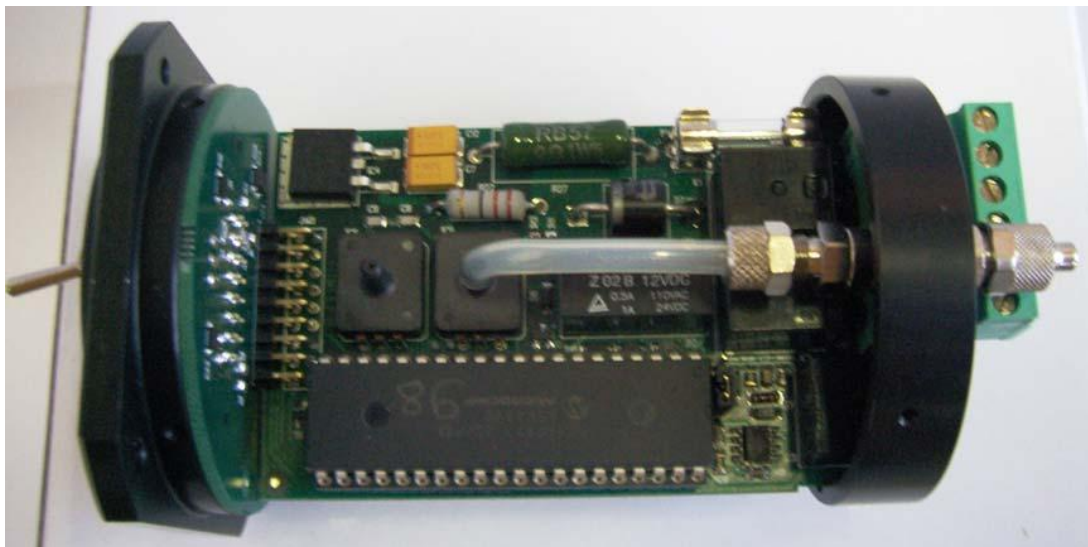

The **Display Unit** is contained within a black PVC round support of standard dimensions (57 mm), suitable to be installed on the dashboard as a normal aeronautical instrument.

It contains several commands and indications.

COMANDS:

- 1) A three position switch to select the functional mode a.
Take Off/Landing,
b. **Manual,**
c. **Automatic/Constant Revs.**
- 2) Two push buttons + – for various adjustments, depending upon the contest. a.
When in mode Constant Revs these push buttons adjust the target
revs within the range 1500 to 3050 RpM.
b. When in manual mode these push buttons increase and decrease the
propeller pitch.
c. During the setup phase, these push buttons increase and decrease the value
of the selected parameter.
- 3) A push button to **Set** up the system parameters.

INDICATIONS:

- 4) A digital LCD display 16 characters, on two rows, wide reading angle. With LED Backlight.
- 5) A **Green LED** indicates the **Minimum** propeller pitch end of range and a **Blue LED** indicates the **Maximum** propeller pitch end of range.



How does Mini C I P work?

Manual Mode:

The pilot may decide to adjust the propeller pitch manually, in case he so desires or in case of system malfunction. Put the switch in **Man** mode and adjust your propeller pitch using the +/- push buttons. Obviously Takeoffs and Landings are executed with the minimum pitch.

Constant Revs. Mode (1500-3050 Giri / Min):

The pilot sets the switch '1' to Auto/Cnst position and pushes the 'Set' in order to read Cst on the bottom left side of the Display.

Then it adjusts the "target" engine Revs by the + or – push buttons. The Target value is shown in the bottom right corner of the display.

The system will adjust the propeller pitch in order to attain the expected engine Revs (Target Value +/- 50 Rpm). This is the traditional mode used

in aeronautics; you get the number of constant revolutions independent of the aircraft flying conditions and independent of the **MaP** (Manifold Pressure), obviously within the technical physics constraints.

Automatic Mode:

The pilot puts the switch "1" to in **Auto/Cnst** and pushes the **Set** button to read "A" on the bottom left corner of the Display.

In this mode the system automatically determines the **Target Revs** based on the **MaP**, in accordance with selected engine power curve and in accordance with the atmospheric pressure.

The atmospheric pressure depends upon the flying altitude. The **Max** and **Min** limits will obviously be the ones previously set up in the system.

The Manifold Pressure MaP is indicated in inches of Hg (Mercury) within the range 0" - 35" and with an accuracy of 1/4".

So **Mini C I P** adjusts your propeller to optimize the engine efficiency. The pilot does not need to intervene on the propeller pitch. He gets all the advantages of a variable pitch propeller without any need to control it.

The advantage of using **Mini C I P** becomes even more evident in the most critical flight phases, when the pilot would have neither the time, nor the chance to control the propeller, as he is too busy flying the aircraft.

Takeoff/Landing Mode

Takeoffs, Goarounds and Landings are executed with the switch 1 in position **Takeoff/Landing**.

In this way the Target Revs value is the one selected during the setup (i.e. 3300 RpM for Jabiru), however, should this phase be longer than 2 ½ minutes the Target Revs would switch to the value setup against the Maximum Continuous value (i.e. 3100 RpM for Jabiru).

Display Description.

P29- 2900

A29/ 2900

P29-

Indicates the Manifold Pressure in inches of mercury: **(29)**
and in inch quarters:

Indication	Value
\	1/4"
-	1/2"
/	3/4"

2900 on top line

Indicates the engine revs.

2900 on bottom line

Indicates the target revs. When engine revs coincide with target revs, the propeller pitch is adjusted onto the correct value

Man

Indicates that the system is in **Manual** Mode.

A29/

Indicates the Atmospheric Pressure in inches of mercury: **(29)**
and in inch quarters:

Indication	Value
\	1/4"
-	1/2"
/	3/4"

The Atmospheric pressure varies with the altitude.

In this example it indicates 29" and 3/4" of Hg. Typically the atmospheric pressure decreases by 1" every 1000 feet.

When Cruising, the system determines the Target Revs based on the MaP, it essentially follows the torque curve of the selected engine; however it also takes into account the Atmospheric pressure, which depends upon the altitude.

Installation.

Mechanical Installation

Jabiru engines require the use of a REV's Pick up BALLUFF BES 516- 324-E4-C-03.

- A. This proximity sensor is to be installed on a supporting bracket which holds it near the aluminium rotating hub of the propeller.
- B. The aluminium propeller hub must have a pair of 6 mm steel bolts mounted 180 degrees from each other. It is important that the steel bolts are installed on an aluminium rotating body or else the sensor will not be able to read the magnetic fields.
- C. The sensor will see the two bolts passing by for each and every propeller revolution so that your governor can count the number of passages per time unit.
- D. The gap between the sensor head and the bolts' head is to be adjusted as close as possible, however less than 1 mm.
- E. Make sure that the supporting bracket does not vibrate when the engine is running or you may have either false readings or mechanical interferences between the bolts and the sensor head or both.

Electric Installation

Jabiru engines require the use of a REV's Pick up BALLUFF BES 516-324-E4-C-03

The Unit has a six-pin connector on the back.

From the right end side moving to the left we find:

- A) **Positive pin.** Connect the positive +12V through a switch and a fuse (or a thermal circuit breaker) on the dashboard. Such fuse is to be of a value suitable to supply the proper current to the installed propeller. Usually 50% more than the max current drawn in normal operations.
- B) **Negative pin.** Connect to Gnd and to the **Blue wire of the REV's Pickup**

- C) **PROP** two pins in the centre are to be connected to the propeller motor. See 'Functional Test', further on, to determine their polarity.
- D) **REVs** wire is to be connected to the **Black wire of the REVs Pick up.**
- E) **NC** Connected it to the **Positive wire of the REVs Pick up, Brown wire.**

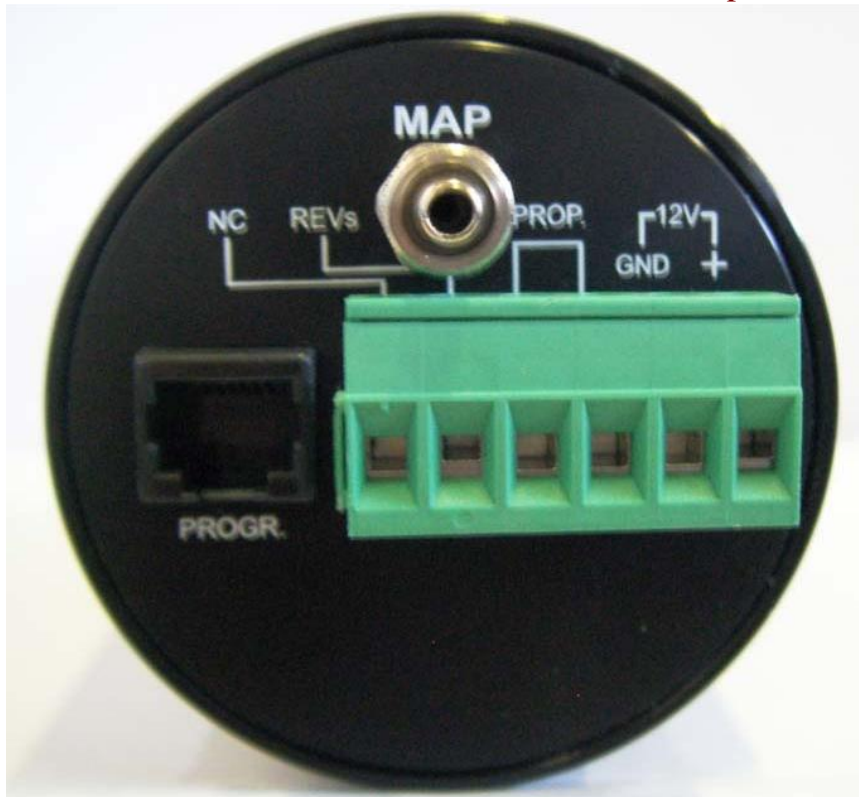

Pneumatic Installation

⊙ MaP

The MaP inlet is to be connected through a plastic hose of 4 mm of internal gauge to the engine MaP outlet.

Notice: *Insert a paper filter inside the hose before connecting it to the unit. The paper filter can be of the type used as cigarette filter. It needs to be squeezed in the hose possibly using some talc to ease it in. Failure to install the filter could cause petrol fumes reaching the pressure sensor with consequent misreading of pressure values.*

Functional test.

- 1) Connect only the power plug. Make sure that:
- 2) Switch on the master and the Mini **C I P** switches.
- 3) Observe the display, you should see a similar reading to this:

P30 0000
Man 000A

Should the script not appear, make sure the 12V is ON, particularly check fuses and polarities; with inverted polarities the fuse blows and the **Unit** may get damaged.

Notice the **Unit** will stay in **Manual** mode even if Switched to **Cst Aut** or takeoff because the engine is not running.

The propeller motor current reads **000A** (bottom line) and the top line reads **0000**.

- 4) Keep the Unit in **Manual**.
- 5) Try to Increase and Decrease the Pitch by using the PITCH Switch + / Listen to the relays activating on the **Main Unit**; notice the LED's, the green light, should go on when activating **Pitch -**, the blue light, should go on when activating **Pitch +**.
- 6) Increase the propeller pitch (+); make sure the pitch of the propeller does increase.
- 7) Decrease the propeller pitch (-); make sure the pitch of the propeller does decrease.
In case the pitch went the opposite directions, reverse the wires at the propeller electric brushes.
- 8) Make sure the propeller pitch motor stops at the two end positions.
The **Green LED** must light when the propeller reaches the **Minimum** pitch.
The **Blue LED** must light when the propeller reaches the **Maximum** pitch.
- 9) While you manually increase or decrease the propeller pitch, you can read the value of the intensity of the current drawn by your propeller motor.
The value is shown on the right bottom corner of your Display and is indicated with an accuracy of 1/10 of Ampere.
This read value will increase or it will drop to zero when the propeller reaches one of the two ends of its range.
It drops to zero when one of the “end of range” micro-switches opens the electric circuit thus stopping the propeller motor.
It increases if the propeller does not mount “end of range” micro-switches and the blades reach their mechanical end of range.
Adjust the threshold current value as explained further down in the setup section.

NOTICE, if your propeller does not mount end of range micro-switches, when you are in **Manual** mode, let the push button off as soon as the propeller blades reach their **Max** or **Min** mechanical limit.

When the system is in **Automatic** or **Constant** revs mode, when the blades reach their end positions, the circuit is opened automatically by the CIP, providing the setting up of the current thresholds is correct.

- 10) Switch off Min **C I P**.
- 11) Start the engine.
- 12) Switch on the Min C I P.
- 13) Make sure the indicated Revs are correct. If the Revs counter does not work, Mini CIP remains in forced **Manual** mode, no matter the mode selected by the selector switch.
- 14) Switch to **Constant** mode by pushing the Set button and observe the script **C** on the bottom display line. Using + or – push buttons, the target Revs range from **1500** to **3050**.
- 15) Set it to 1500 and rev the engine up to more than 1500. Observe that after the reaction time of the propeller, the engine should rev down to 1500 +/- 50 Revs.
- 16) Switch to **Takeoff** and observe the script **3300** (Takeoff 3300) and eventually the **green LED lit**.

In case of malfunctions

If the MaP sensor does not work.

The system will still work in Constant and in Manual mode.

If the Revs counter does not work.

The system will force to Manual mode. This Display will show:

③ **Man 000A**. On the bottom line. If the computer does not work.

The system will still work in **Manual** mode.

Electric protection of Mini C I P

CIP comes with a 20 Ampere fuse on the main unit.

In addition a dash board fuse or a thermal circuit breaker is to be installed to protect the assembly “Propeller – CIP”.

The value of such fuse is normally double the normal propeller current.

As an example, if a propeller requires an average of 7 Amps to work the thermal circuit breaker on the dash board is to be 15 Amps.

Adjustment of the threshold current to supply to the propeller motor

The propeller current threshold depends upon the type of propeller mounted. In fact every propeller absorbs its specific current. However when the blades approach one of the

two end positions the absorbed current increases considerably and proportionally with the increased effort of the motor.

Some propellers will never reach this condition thanks to “end of range micro - switches” that open the electric circuit before the blades get to their mechanical ends.

Mini CIP can find out when the blades are at their end positions with both types of propellers with or without micro-switches.

The propeller current threshold is to be set up on a case by case basis, usually the current threshold value is adjusted for the Minimum (Green) to 50% more than the current used by the propeller when it decreases the pitch.

Also, the current threshold value is adjusted for the **Maximum (Blue)** to 50% more than the current used by the propeller when it increases the pitch.

System Setup

To enter the setup mode switch on Custom Intelligent Propeller while pushing the Set button on the Display Unit.

If, however, CIP is in **Manual** mode, the setup mode does not activate.

If it is in **Automatic Constant** mode, all the values previously set by the user are kept and may be either confirmed, increased or decreased one at the time.

If in Takeoff mode, the values of all parameters are returned back to their defaults and may be confirmed, increased or decreased one at the time.

The system parameters are shown one at the time to allow the user to confirm or change them.

The current value of the parameter under focus is shown on the display and it may be confirmed by pushing the Set button, soon after the system will show the next parameter.

The value of the parameter under focus may also be increased or decreased using repeatedly the push buttons + / - until the wanted value is obtained, then the parameter is confirmed as explained above.

When all parameters are scrolled and confirmed, the system switches to normal mode.

The parameters which may be changed are the following:

1. **“Curr Adj. Grn”** Adjusting of the threshold current absorbed by the propeller pitch motor when the blades are approaching close to the Minimum pitch.
2. **“Curr Adj. Blu”** Adjusting of the threshold current absorbed by the propeller pitch motor when the blades are approaching close to the Maximum pitch.
3. **“User Crr”** Revs value, user chosen, to offset the engine power curve in accordance with the user desire.

4. **“Max Crus”** Maximum revs number during the cruising phase for both aspirated and turbo charged engines.
5. **“Min Revs”** Minimum revs number during the cruising phase for both aspirated and turbo charged engines.
6. **“Takeoff”** This revs value is kept during the take off for the first 2 ½ minutes. If the take off lasted longer the system switches to the take off revs low value.
7. **“Max Cont”** Maximum Continuous. This value is kept during take off after the first 2 ½ minutes.
8. **“Aspir0 Turbo1”** Select 0 for aspirated and 1 for turbo engines.
9. **Map Atm.** The system shows both Manifold and Atmospheric pressure. When the engine is off the two values must coincide. In case of difference, adjust the Atm the same as the MaP.

Notes on the mechanical set up of the propeller

We suggest adjusting the mechanical minimum of the propeller pitch as to allow for a number of maximum revs slightly less than the maximum recommended by the engine vendor for the take off phase.

As an example, for Jabiru engines 80 and 120 HP we suggest to adjust the maximum revs when the aircraft is in a stand still position at 3200- 3250 revs. The maximum REVs being 3300 revs.

The maximum pitch should be some 10 degrees more than the minimum.

A test for propellers with Jabiru engines:

1. Make sure the aircraft brakes are engaged so that the aircraft cannot move and the engine is at its normal working temperature.
2. CIP in Manual mode. Adjust the Propeller to its Minimum pitch, put the engine full throttle, Revs should read 3200 RpM.
3. With the engine at its maximum power, increase the propeller pitch and observe the Revs decreasing, when the pitch reaches its Maximum the Revs should be 1500 RpM.
4. Switch to Constant mode and adjust the Target Revs, using the CIP knob, to 3150 and then to 1500. The engine revs should adapt and follow your target values.

The first Flight

If all the listed tests were positive, fly your aircraft with the **C I P Custom Intelligent Propeller** in **Manual Mode**, taking off with the propeller at minimum pitch (Green LED lit). Obviously make sure not to exceed the Maximum engine revs as you take up speed, in case it happens you need to increase the propeller pitch manually as necessary.

Switch to **Automatic** mode only, after reaching the safety height and only if the values of the Revs., Speed and MaP are reliable and trustworthy.

Change flying conditions to force **C I P Custom Intelligent Propeller** to adjust the pitch in all possible flying conditions.

Take off and land in automatic mode only after you have gained more than enough confidence in the system and certainly not before having tested it thoroughly.

Responsibility and liability

Responsibility and liability is totally and utterly with the Pilot and with the owner of the aircraft. In no circumstances we are responsible for damage to people or goods.

We remind you that for safety reasons take offs and landing should be executed in manual mode with the pitch adjusted to the minimum.